

OV5690 5-megapixel product brief



High-Performance 5-megapixel Image Sensor for Slimmer Mobile Devices



available in
a lead-free
package

The OV5690 is OmniVision's most advanced 1/4-inch, 5-megapixel image sensor to date, combining DSC-quality imaging with full 1080p high-definition (HD) video recording. Using OmniVision's proprietary 1.4-micron OmniBSI-2™ pixel architecture, the OV5690 offers best-in-class low-light performance and image quality while also enabling 20 percent thinner camera modules compared to other 1/3.2-inch sensors. This makes the OV5690 an effective solution for ultra-slim camera designs for next-generation mobile handsets, smart phones and tablets.

Utilizing OmniVision's extremely efficient second-generation backside illumination technology, the OV5690 offers advanced features including 30 frames

per second full resolution frame rate, an integrated scaler, and 2 x 2 binning functionality with re-sampling filter. The scaler enables electronic image stabilization, while maintaining full field of view in both 720p and 1080p HD video modes. The 2 x 2 binning functionality, which features a post-binning re-sampling filter, further increases the sensor's sensitivity while minimizing spatial artifacts and removing image artifacts around edges to produce crisp, clean color images.

The sensor features a standard 2-lane (1 Gbps/lane) MIPI interface and fits into the industry standard 8.5 x 8.5 mm module size with a z-height as low as 4.5 mm.

Find out more at www.ovt.com.

Applications

- Cellular and Mobile Phones
- Digital Video Camcorders (DVC)
- Digital Still Cameras (DSC)
- PC Multimedia

Product Features

- automatic black level calibration (ABLC)
- programmable controls for frame rate, mirror and flip, cropping, windowing, and scaling
- image quality controls: lens correction and defective pixel canceling
- supports output formats: 10-bit RAW RGB (MIPI)
- supports horizontal and vertical subsampling
- supports images sizes: 5 Mpixel, EIS1080p, 1080p, 720p, VGA, QVGA
- fast mode switching
- support 2x2 binning, full scalar
- standard serial SCCB interface
- up to 2-lane MIPI serial output interface
- embedded 512 bytes one-time programmable (OTP) memory for part identification, etc.
- two on-chip phase lock loop (PLL)
- programmable I/O drive capability
- built-in 1.2V regulator for core
- built-in temperature sensor
- supports alternate row HDR timing

OV5690

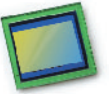

Ordering Information

- OV05690-G04A
(color, chip probing, 200 μm backgrinding, reconstructed wafer with good die)

Product Specifications

- active array size: 2592 x 1944
- power supply:
 - core: 1.2V \pm 5%
 - analog: 2.6 - 3.0V
 - I/O: 1.7 - 3.0V
- power requirements:
 - active: 155 mA
 - standby: 10 μA
- temperature range:
 - operating: -30°C to 70°C junction temperature
 - stable image: 0°C to 50°C junction temperature
- output formats: 10-bit RGB RAW
- lens size: 1/4"
- lens chief ray angle: 24.1° non-linear
- input clock frequency: 6 - 27 MHz
- max S/N ratio: 36 dB
- dynamic range: 71.6 dB @ 8x gain
- maximum image transfer rate:
 - 5 Mpixel: 30 fps
 - EIS1080p: 30 fps
 - 1080p: 30 fps
- sensitivity: 780 mV/lux-sec
- scan mode: progressive
- maximum exposure interval: 2480 x t_{ROW}
- pixel size: 1.4 μm x 1.4 μm
- dark current: 0.26 mV/s @ 50°C junction temperature
- image area: 3673.6 μm x 2738.4 μm

Functional Block Diagram

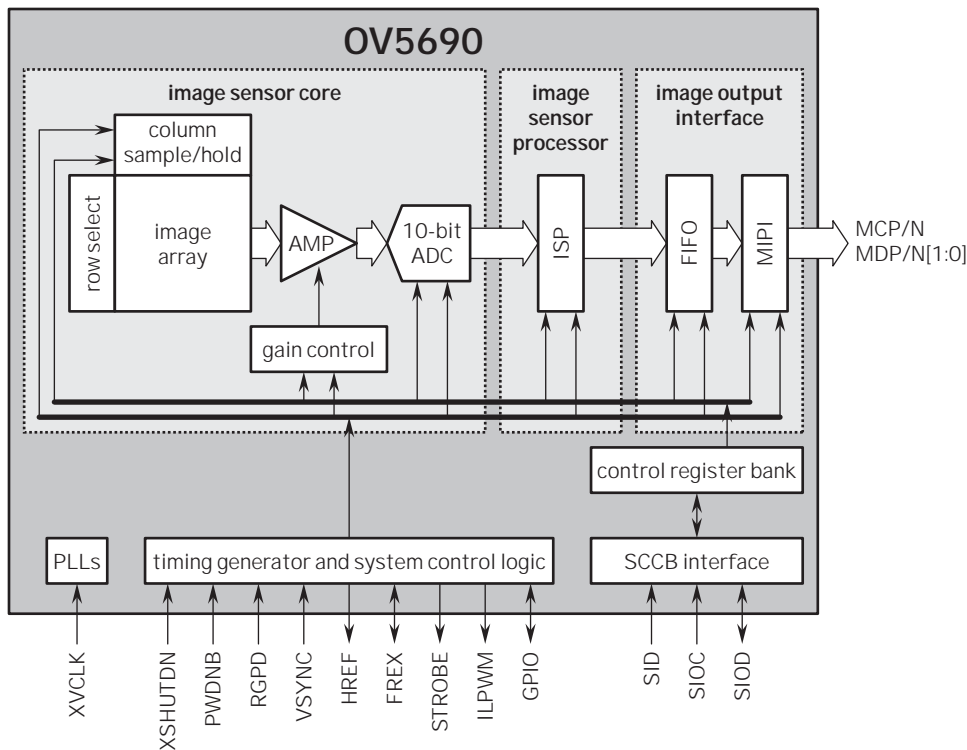

4275 Burton Drive
Santa Clara, CA 95054
USA

Tel: + 1 408 567 3000
Fax: + 1 408 567 3001
www.ovt.com

OmniVision reserves the right to make changes to their products or to discontinue any product or service without further notice. OmniVision, the OmniVision logo and OmniPixel are registered trademarks of OmniVision Technologies, Inc. OmniBSI-2 is a trademark of OmniVision Technologies, Inc. All other trademarks are the property of their respective owners.

OmniVision